

Wall Stiffener System

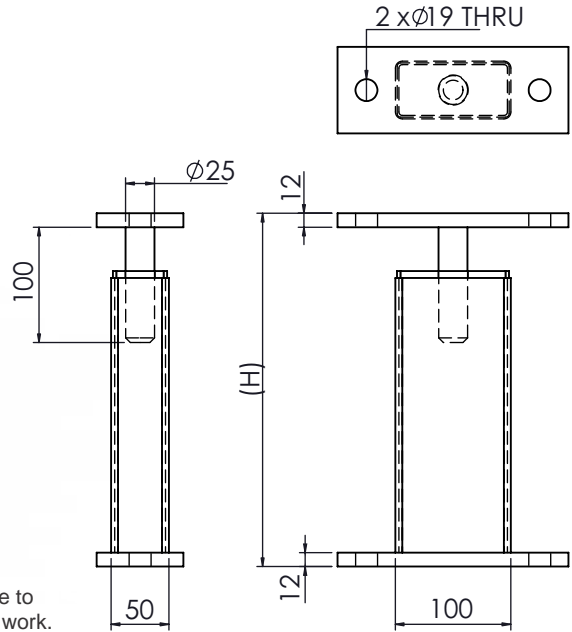

DESCRIPTION

Cerra wall stiffeners system is a simple but incredibly effective alternative to traditional wind posts and heavyweight precast concrete lintels for block work.

FEATURES

- Best aesthetic solution
- Internal with no acoustic, fireproofing issues .
- Standard block thicknesses , no projections
- Standardised and tested componentry.
- Suit all Australian standard block work sizes 140 / 190 / 290 mm
- Easily customized fixing plates

CORROSION CHARACTERISTICS

Hot dipped galvanising (R3)
 Conforms to corrosion resistance set by AS/NZS 2699.2:2020 / AS 3700.

ORDERING INFORMATION

When ordering please supply use with the part number and quantity you require

WS1-100x50x3-2400-R4

PRODUCT CODE	SIZE	HEIGHT (mm)	MATERIAL
	100x50x3 RHS		Specify
	125x75x6 RHS		R3 for Hot dipped galvanising
	65x65x6 SHS		
	75x75x6 SHS		



Datasheet